

2-5. Caution for Ducting Work

- This unit has high static pressure.
- In case of small pressure resistance (for instance, a short duct), install an airflow control damper (field supply) for adjusting airflow volume as airflow volume / airflow noise increases.
- If the air conditioner is to be installed in a room such as an office or meeting room which requires a low sound level, provide a supply and return sound absorption chamber with an acoustic liner.
- Use a flexible canvas connection or vibration isolation hanger (field supply) to break transmission of mechanical vibration of the unit.

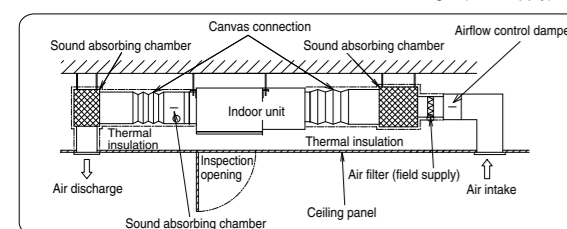

CAUTION

- Use incombustible duct materials.
- Use thermal insulation to prevent duct condensation.
- An air filter (field supply) must be installed at the air intake side. If not installed, the heat exchanger will get dirty and the unit will reduce the quality.
- Obtain and install an air filter (field supply) which can easily wash away the dust by lukewarm, soapy water or suck up with a vacuum cleaner.
- Clean the air filter periodically to collect dust and other particles from the air.
- Use duct static pressure within a range of specification value.

3 ELECTRICAL WIRING

As to main power source and cable size of outdoor unit, read the installation manual attached to the outdoor unit.

3-1. General Precautions on Wiring

- This air conditioner must be installed in accordance with national wiring regulations.
- Cables connected to indoor unit must be approved polychloreprene sheathed type 60245 IEC 57 or heavier.
- The units must be connected to the supply cables for fixed wiring by qualified technician.
- Circuit breaker must be incorporated in the fixed wiring in accordance with the national wiring regulations. The circuit breaker must be approved, suitable for the voltage and current ratings of equipment and have a contact separation by 3mm in all poles.
- When the supply cable is damaged, it must be replaced by qualified technician.
- Be sure to install a current leakage breaker, main switch and fuse to the main power supply, otherwise electric shocks may result.
- Be sure to connect the unit to secure earth connection.
- If the earthing work is not carried out properly, electric shocks may result.
- Wiring shall be connected securely by using specified cables and fix them securely so that external force of the cables may not transfer to the terminal connection section.
- Imperfect connection and fixing leads to fire, etc.

- Select a power source that is capable of supplying the current required by the air conditioner.
- Feed the power source to the unit via a distribution switch board designed for this purpose, the switch should disconnect all poles with a contact separation of at least 3 mm.
- Always ground the air conditioner with a grounding wire and screw to meet the LOCAL REGULATIONS.
- Be sure to connect the indoor/outdoor unit connection wires correctly to terminal board.
- Be sure to turn off the main power before installing and connecting the remote controller.
- Each wiring connection must be done in accordance with the wiring system diagram.

Wrong wiring may cause the wires overloaded and overheated.

3-2. Wiring System Diagrams

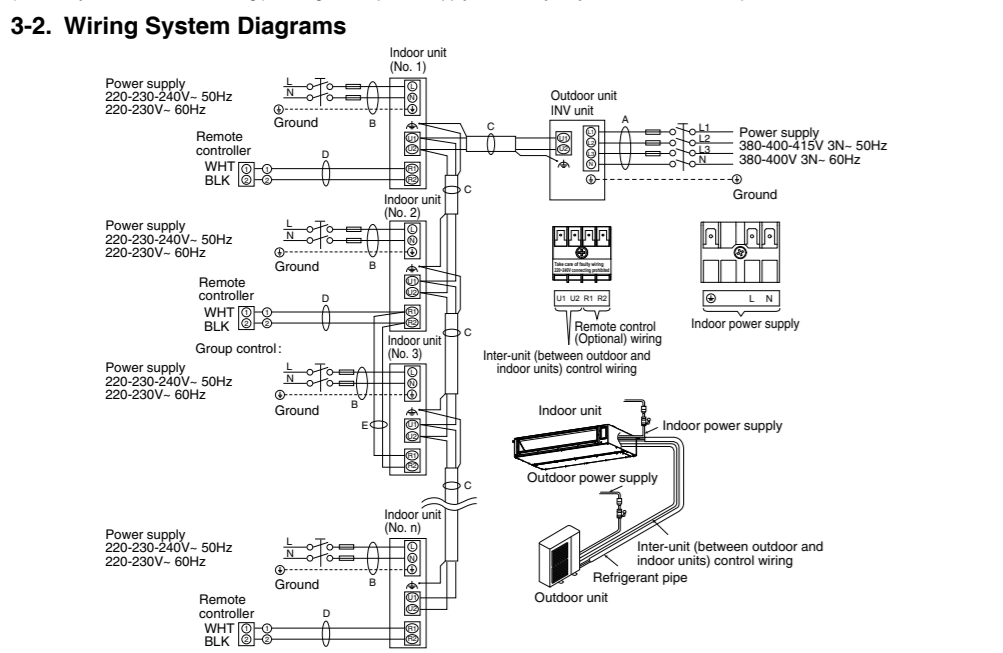

NOTE: See the section "3-3. Recommended Wire Length and Wire Diameter for Power Supply System" for explanation of "A", "B", "C", "D", and "E" in the above diagram.

- The basic connection diagram of the indoor unit shows the 6P terminal board, so the terminal boards on your equipment may differ from the diagram.
- Attach the terminal cover after fixing the wires at the terminal board.

3-3. Recommended Wire Length and Wire Diameter for Power Supply System

Model	Power Supply	Recommended Wire Length and Wire Diameter for Power Supply Cable								Time Delay Fuse or Circuit Capacity (A)
		Min. Wire Size (mm ²)	Max. Length (m)	Min. Wire Size (mm ²)	Max. Length (m)	Min. Wire Size (mm ²)	Max. Length (m)	Min. Wire Size (mm ²)	Max. Length (m)	
S-180MESH	220-230-240V~ 50Hz	1.5	26	2.5	43	4.0	69	6.0	104	10
S-224ME3H	220-230-240V~ 50Hz	1.5	23	2.5	39	4.0	62	6.0	93	10
S-280ME3H	220-230-240V~ 50Hz	1.5	23	2.5	39	4.0	62	6.0	93	10

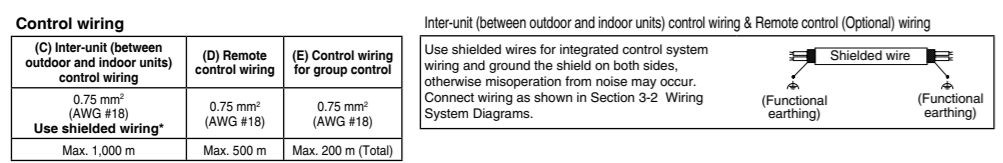

NOTE: For outdoor unit wire length and wire diameter for power supply system (A), refer to the installation instruction manual that comes with that outdoor unit. For Optional Parts connecting wiring size, refer to Installation Manual of the Optional Parts.

- If branching in the inter-unit control wiring, the number of branch points should be 16 or fewer.

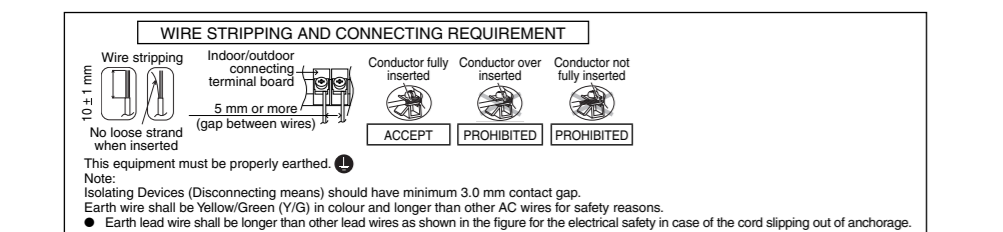
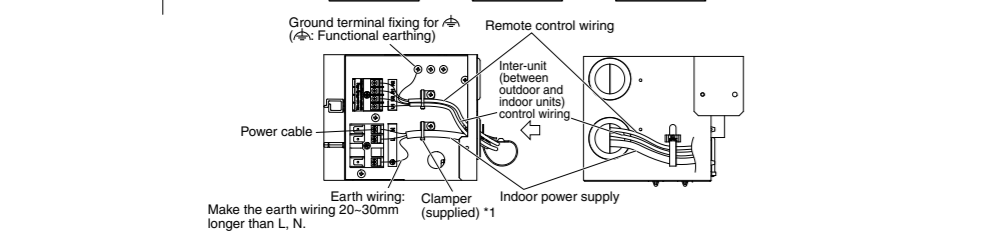
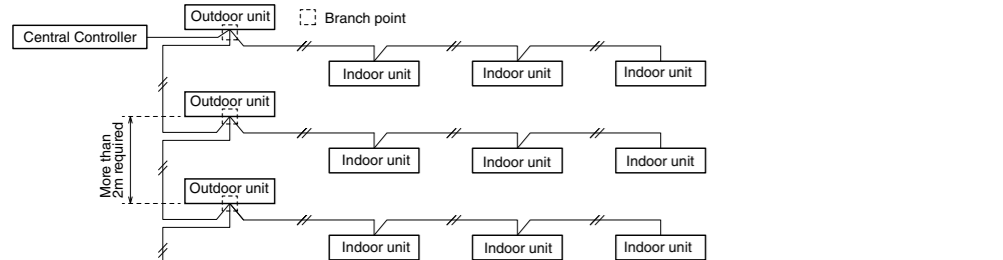

4 REFRIGERANT PIPING

Must ensure mechanical connections be accessible for maintenance purposes. The liquid tubing side is connected by a flare nut, and the gas tubing side is connected by brazing.

4-1. Connecting the Refrigerant Tubing

- Replace air inside the tube with nitrogen gas to prevent copper oxide film from forming during the brazing process. (Oxygen, carbon dioxide and Freon are not acceptable.)
- Do not allow the tubing to get too hot during brazing. The nitrogen gas inside the tubing may overheat, causing refrigerant system valves to become damaged. Therefore allow the tubing to cool when brazing.
- Use a reducing valve for the nitrogen cylinder.
- Do not use agents intended to prevent the formation of oxide film. These agents adversely affect the refrigerant and refrigerant oil, and may cause damage or malfunctions.

4-2. Connecting Tubing Between Indoor and Outdoor Units

- Tightly connect the indoor-side refrigerant tubing extended from the wall with the outdoor-side tubing.

Indoor unit type	180/224	280
Gas tubing (mm)	ø19.05	ø22.22
Liquid tubing (mm)		ø12.7

- To fasten the flare nuts, apply specified torque.
 - When removing the flare nuts from the tubing connections, or when tightening them after connecting the tubing, be sure to use a torque wrench and a spanner. If the flare nuts are over-tightened, the flare may be damaged, which could result in refrigerant leakage and cause injury or asphyxiation to room occupants.
 - For the flare nuts at tubing connections, be sure to use the flare nuts that were supplied with the unit, or else flare nuts for R410A, R32 (type 2). The refrigerant tubing that is used must be of the correct wall thickness as shown in the table below.

Tube diameter	Flare nut tightening torque (approximate)	Min. tube thickness
ø12.7 (1/2")	55±6 Nm (550±60 kgfcm)	0.8 mm (Material Temper - O)
ø19.05 (3/4")	-	1.2 mm (Material Temper - O)
ø22.22 (7/8")	-	1.0 mm (Material Temper - 1/2 H + H)

- Because the pressure is approximately 1.6 times higher than conventional refrigerant R22 pressure, the use of ordinary flare nuts (type 1) or thin-walled tubes may result in tube rupture, injury, or asphyxiation caused by refrigerant leakage.
- In order to prevent damage to the flare caused by over-tightening of the flare nuts, use the table above as a guide when tightening.
- When tightening the flare nut on the liquid tube, use an adjustable wrench with a nominal handle length of 200 mm.

4-3. Insulating the Refrigerant

- Selection of heat insulation materials for refrigerant tube. When using heat insulation materials (field supply), kindly check for its insulating performance.
- Material for insulation material: Polyethylene foam.
- Heat transfer rate: less than 0.051W/m·K.
- Material withstand temperature: 120°C or above (gas tubing).
- For other tubing 80°C or above.
- Must be easy to use, age resistance and not easily absorb moisture.
- Be sure to match the below insulation material size with tube sizes.

Piping size, mm (In)	Thermal insulation size (I.D.)	Thermal insulation Thickness
12.7 (1/2")	14 - 16 mm	Insulation thickness must be 10mm or greater
19.05 (3/4")	20 - 24 mm	
ø22.22 (7/8")	22 - 25 mm	

- Taping the flare nuts
 - Wind the white insulating tape around the flare nuts at the gas tube connection.
 - Then cover up the tubing connection with tube insulator (field supply) and fill in the gap with black insulation tape.
 - Finally fasten with clampers (field supply).

NOTE: If noise bothers you from the area between indoor and outdoor units' connection pipes, it is effective to wind the soundproofing materials (field supply) to reduce noise.

- Finishing the installation
 - After finishing insulating and taping over the tubing, use sealing putty to seal off the hole in the wall to prevent rain and draft from entering.
 - Precautions in high humidity circumstances
 - This air conditioner has been tested according to the "JIS Standard Conditions with Mist" and have been confirmed that there are no faults. However, if it is operated for a long time in high humid atmosphere (dew point temperature: more than 23 °C), water drops are liable to fall. In this case, add heat insulation material according to the following procedures:
 - Heat insulation material to be prepared. Adiabatic glass wool with thickness 10-20mm
 - Stick the wool on all air-conditioners that are located in the ceiling atmosphere
 - In addition to the normal heat insulation (thickness: more than 10mm) refrigerant piping, add a further of 10-30 mm thickness material.

- Additional Precautions for R410A models
 - For connection joint of all models
 - Please make flare after inserting flare nut (locate at joint portion of tube assembly) onto the copper pipe. (In case of using long piping)
 - Connect the piping
 - Align the center of piping and sufficiently tighten the flare nut with fingers.
 - Further tighten the flare nut with torque wrench in specified torque as stated in the table.

NOTE: If the exterior of the outdoor unit valves has been finished with a square DUT covering, make sure you allow sufficient space to access the valves and to allow the panels to be attached and removed.

- Finishing the installation
 - After finishing insulating and taping over the tubing, use sealing putty to seal off the hole in the wall to prevent rain and draft from entering.
 - Precautions in high humidity circumstances
 - This air conditioner has been tested according to the "JIS Standard Conditions with Mist" and have been confirmed that there are no faults. However, if it is operated for a long time in high humid atmosphere (dew point temperature: more than 23 °C), water drops are liable to fall. In this case, add heat insulation material according to the following procedures:
 - Heat insulation material to be prepared. Adiabatic glass wool with thickness 10-20mm
 - Stick the wool on all air-conditioners that are located in the ceiling atmosphere
 - In addition to the normal heat insulation (thickness: more than 10mm) refrigerant piping, add a further of 10-30 mm thickness material.

4-4. Additional Precautions for R410A models

- Vacuum Drying
 - After completing the piping connection, execute vacuum drying for the connecting piping and the indoor unit. The vacuum drying must be carried out by using the service ports of both the liquid and gas side valves.

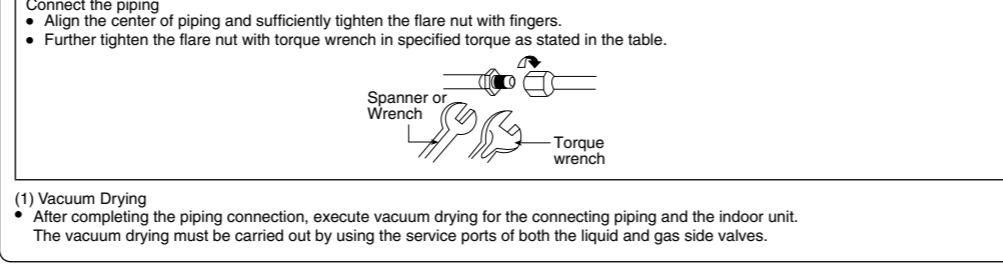

5 HOW TO INSTALL THE TIMER REMOTE CONTROLLER OR HIGH-SPEC WIRED REMOTE CONTROLLER (OPTIONAL PART)

NOTE: Refer to the Installation Instructions attached to the optional Timer Remote Controller or optional High-spec Wired Remote Controller.

- Request that the customer be present when the test run is performed. At this time, explain the operation manual and have the customer perform the actual steps.
- Check that the 220-230-240 VAC power is not connected to the U1 & U2 terminal board terminal.
- If 220-230-240 VAC is accidentally applied, the Fuse on indoor unit Electronic Controller (Communication) will blow in order to protect the PCB.
- In this case, recover the connection by disconnect 2P connector wires that originally connected to the indoor unit Electronic Controller (Communication) OC connector and shift the connector wires to EMG connector on same indoor unit Electronic Controller (Communication). If operation is still not possible after shift to EMG connector, cut the jumper JP040 on the same indoor unit Electronic Controller (Communication).

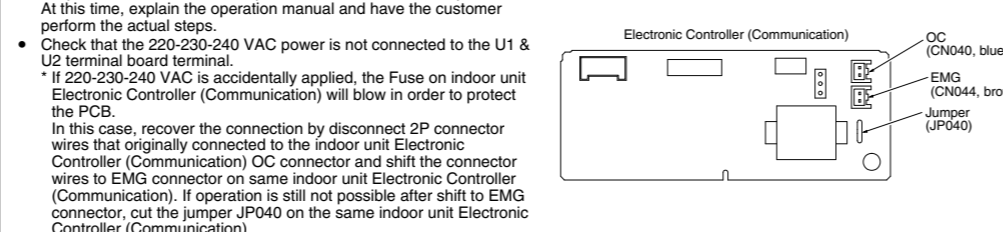

7 EXTERNAL STATIC PRESSURE SETTING

Choose one of the methods (selection of "a", "b", "c" within the range of dotted line as shown in the flowchart below) and make settings.

- No setting changes: When using as it is factory preset at shipment.
- Manual setting (on indoor unit Electronic Controller (Main)): If resetting after external static pressure setting once, it might be different from factory preset.
- Manual setting (by wired remote controller): Static pressure setting excepting factory preset at shipment.

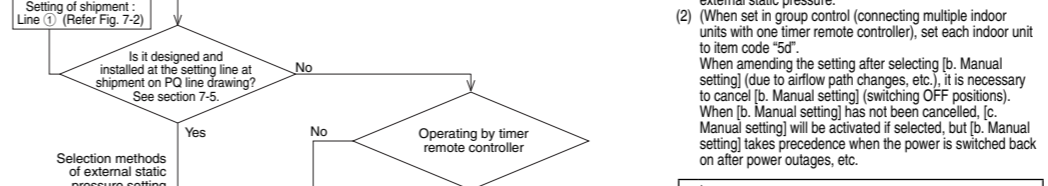

- Make sure the external static pressure is in a range of specifications.
- Then proceed the external static pressure setting. Improper settings can cause noise, a shortage of airflow volume and water leakage.
- Refer to Fig. 7-2 for the external static pressure setting range.
- Be sure to set the [External Static Pressure Setting] once again after extending the airflow path for the duct or air outlet after setting the external static pressure.

7-1. How to Set on Indoor Unit Electronic Controller (Main)

- Turn off the power breaker to halt the supply of electricity to the indoor unit Electronic Controller (Main).
- Open the lid of the electrical component box and confirm the location where the Select switch on the indoor unit Electronic Controller (Main) is placed. (Fig. 7-1)
- Set the On/Off switches in the Off position which are now set in the On position.

7-1. External static pressure setting SW setting

External static pressure at the time of rated airflow volume	SW001	TP6	TP3	TP1
180	224/280	ON	ON	ON
180Pa	200Pa	1	2	3
120Pa	130Pa	1	2	3
75Pa	75Pa	1	2	3

7-2. Operating the Timer Remote Controller (CZ-RTC4/CZ-RTC4A)

How to set the external static pressure

- Press and hold down the [ON] and [OFF] buttons simultaneously for 4 or more seconds. (The Unit No., Item Code and Detailed Data will blink on the LCD display.)
- The indoor unit numbers in the group control will be sequentially displayed whenever the Unit Select button is pressed.
- Only the fan motor for the selected indoor unit will operate during this time.
- Specify the "5d" item code by pressing the [5] and [d] buttons for the temperature setting buttons and confirm the values. ("00 0" set at shipment)
- Press the [5] and [d] buttons for the time to amend the values for the set data. Refer to Table 7-2 and Fig. 7-2 and select a value "00 06", "00 03" or "00 01".
- Press the [5] button.
- The display will stop blinking and remain illuminated.
- Press the [5] button. The fan motor will stop operating and the LCD display will return to the normal stop mode.

7-2. Setting the external static pressure

Indoor unit	Item code	
180	224/280	
External static pressure of the rated air flow volume	5d	
180 Pa	200 Pa	00 06
120 Pa	130 Pa	00 03
75 Pa	75 Pa	00 01

7-3. Operating the High-spec Wired Remote Controller (CZ-RTC5B)

How to set the external static pressure

- Keep pressing the [5] and [d] buttons simultaneously for 4 or more seconds. The "Maintenance func" screen appears on the LCD display.
- Press the [5] or [d] button to see each menu. If you wish to see the next screen instantly, press the [5] or [d] button. Select "3. Detailed settings" on the LCD display and press the [5] button. The "Detailed settings" screen appears on the LCD display. Select the "Unit no." by pressing the [5] or [d] button for changes.
- Select the "Code no." by pressing the [5] or [d] button. Change the "Code no." to "5D" by pressing the [5] or [d] button (or keeping it pressed).
- Select the "Set data" by pressing the [5] or [d] button. The "Set data" screen appears on the LCD display. Select one of the "Set data" among "0000", "0003" or "0001" according to the desired external static pressure setting by pressing the [5] or [d] button. (See Table 7-3 and Fig. 7-2.) Then press the [5] button. Press the [5] button and press the [5] button. The "Exit detailed settings and restart?" screen appears on the LCD display. Select "YES" and press the [5] button.

Indoor unit	Item code	
180	224/280	
External static pressure of the rated air flow volume	5d	
180 Pa	200 Pa	00 06
120 Pa	130 Pa	00 03
75 Pa	75 Pa	00 01

7-4. Operating the Wired Remote Controller (CZ-RTC6 series)

Stop the system before performing these steps. How to set the external static pressure

- Keep pressing the [5] and [d] buttons simultaneously for 4 or more seconds. The "Maintenance func" screen appears on the LCD display. Select "3. Detailed settings" on the LCD display. Select the "Unit no." by pressing the [5] or [d] button. After selecting "Unit no.", press the [5] button and proceed to Step 4. If the [5] button is pressed, proceed to Step 6.
- Keep pressing the [5] button for 2 seconds or more during selecting "Code no.". Change the "Code no." one digit at a time so that it becomes [00005D] along with the following procedures. Change the value by pressing the [5] or [d] button. After changing the value, press the [5] button and set the next digit.
- Select one of the "Set data" among "0000", "0003" or "0001" according to the desired external static pressure setting by pressing the [5] or [d] button. (See Table 7-4.) After selecting "Set data", press the [5] button. (If setting continuously, follow the procedures from Fig. A.) If you wish to change the selected indoor unit or finish setting, press the [5] button twice (the display returns to Step 3).

Indoor unit	Item code	
180	224/280	
External static pressure of the rated air flow volume	5d	
180 Pa	200 Pa	00 06
120 Pa	130 Pa	00 03
75 Pa	75 Pa	00 01

7-4. Setting the external static pressure

- Failure to set this parameter may result in decreased airflow and condensation.
- If the [5] button is pressed under the display Step 3, the following display (Detailed setting-screen) appears. Then select "YES" by pressing the [5] or [d] button and press the [5] button.

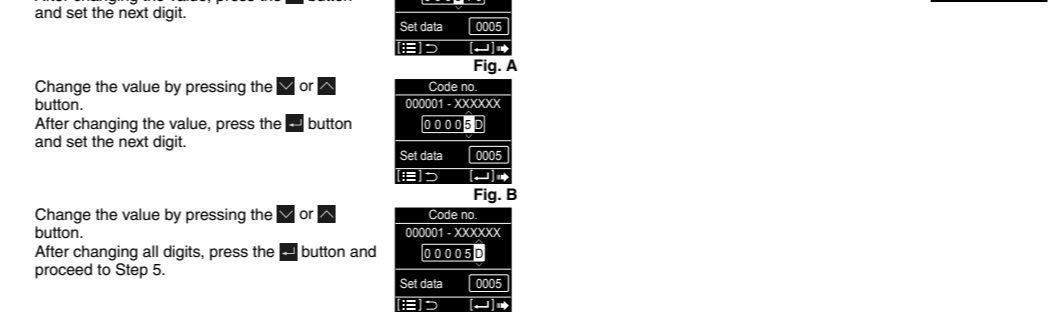

7-5. Indoor Fan Performance

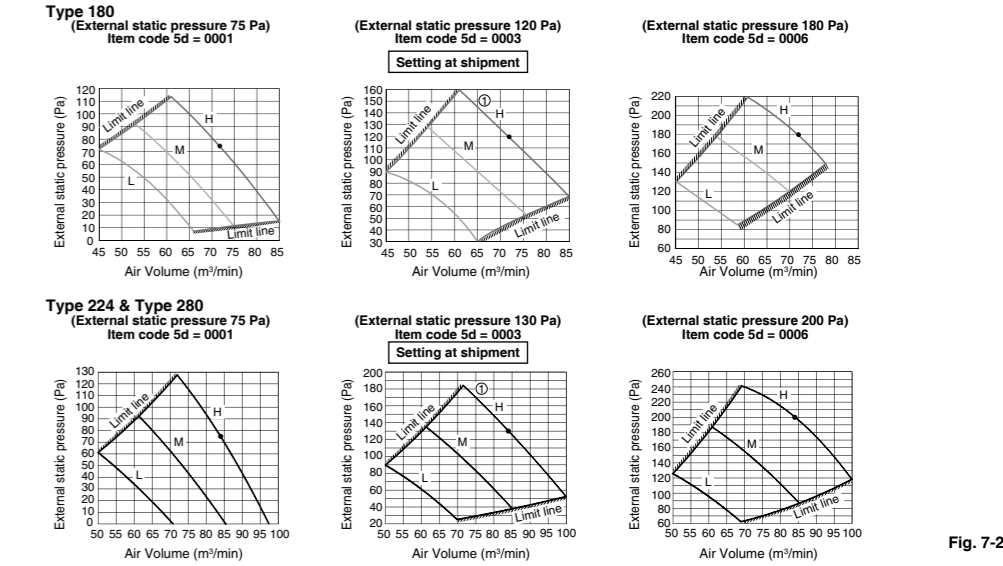
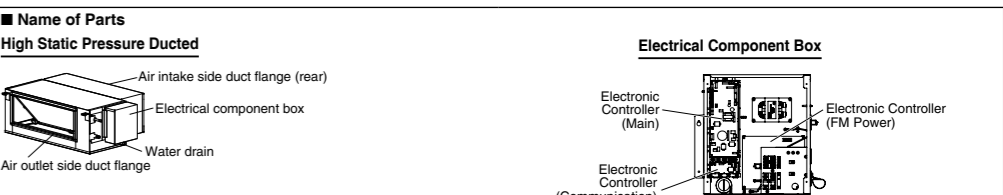

Fig. 7-2

8 APPENDIX



Care and Cleaning

WARNING

- Engage authorized dealer or specialist for cleaning.
- For safety, be sure to turn the air conditioner off and also to disconnect the power before cleaning.
- Do not pour water on the indoor unit to clean it. This will damage the internal components and cause an electric shock hazard.

Air intake and outlet side (Indoor unit)
Clean the air intake and outlet side of the indoor unit with a vacuum cleaner brush, or wipe them with a clean, soft cloth.

- If these parts are stained, use a clean cloth moistened with water. When cleaning the air outlet side, be careful not to force the vanes out of place.

Air filter

- In case of installing the Duct (field supply)

Period (Depends on filter's specifications) When cleaning the air filter, consult your dealer or service center.

CAUTION

- Certain metal edges and the condenser fins are sharp and may cause injury if handled improperly; special care should be taken when you clean these parts.
- The internal coil and other components must also be cleaned periodically. Consult your dealer or service center.

Care: After a prolonged idle period

Check the indoor and outdoor unit intakes and outlets for blockage; if there is a blockage, remove it.

Care: Before a prolonged idle period

- Operate the fan for half a day to dry out the inside.
- Disconnect the power supply and also turn off the circuit breaker.
- Clean the air filter and replace it in its original position.

NOTE

Should the power fall while the unit is running
If the power supply for this unit is temporarily cut off, the unit will automatically resume operation once power is restored using the same settings before the power was interrupted.

Important Information Regarding The Refrigerant Used

NOTE: Refer to the Installation Instructions attached to the outdoor unit.

CHECK THE FOLLOWING ITEMS WHEN INSTALLATION IS COMPLETE

- After completing work, be sure to measure and record trial run properties, and store measuring data, etc.
- Measuring items are room temperature, outside temperature, suction temperature, blow out temperature, unit velocity wind volume, voltage, current, presence of abnormal vibration and noise, operating pressure, piping temperature, compressive pressure, airleak pressure.
- As to the structure and appearance, check the following items.
 - Is circulation of air adequate?
 - Is there any leakage of refrigerant?
 - Are the terminal screws loosened?
 - Is draining smooth?
 - Is remote controller switch operated?
 - Is heat insulation complete (refrigerant and drain piping)?
 - Is there any faulty wiring?

HAND OVER

- Teach the customer the operation and maintenance procedures, using the operation manual (air filter cleaning, temperature control, etc.)
- Refer to installation manual of optional parts (sold separately).

As for work specifications of the outdoor unit, read the OUTDOOR UNIT INSTALLATION MANUAL attached to the outdoor unit.